



Accelerating  
the future  
of aerospace

# How to flight test your antennae?

PRODUCTS & SERVICES



## Try NLR's antenna-box-equipped test aircraft

At stake is the flight testing of your aircraft antennae together with their application systems. However, you do not want to spend large amounts of time and budget. NLR's flight test facility provides an affordable way forward. Our Cessna Citation II test aircraft is equipped with an external mounting structure or 'antenna box', allowing for easy and quick installation of antennae. Due to its size, our aircraft has low operating cost, yet comparably performs to large transport aircraft.



## WHAT YOU NEED

- Flight test platform to evaluate antennae systems and their applications
- Short time between
  - project initiation and flight test execution
  - testing of different antennae
- Flexible operation, incl. test location
- Low cost services

## WHAT WE DELIVER

- Accommodate your antenna system on our aircraft
  - Antenna box on top of fuselage
  - Antenna positions on bottom of fuselage
- Accommodate supporting/application systems in our aircraft
- Modify aircraft if required (design, manufacturing, certification)
- Instrument our aircraft to collect flight test data
- Perform test flights from Amsterdam or elsewhere
- Provide guidance/support during all parts of entire project cycle

## OUR CAPABILITIES

### Antenna box

The antenna box consists of a structure which houses three, identical-sized, flat, stringer-supported, sheet metal plates covering a total length of 2,0 m. Antennae can be easily installed on/over these plates. Potential diplexers/amplifiers can be installed on the inner side of the box. Pressure cabin feed through provision for large signal- and coax cables is available. Due to our aircraft size, antennae are always close to their receivers. The antenna box is part of our certified flight test systems and can be readily used.

The antenna box allows for:

- quick and easy installation/removal of antennae as no adapter plates are required
- short aircraft down time as antenna-to-plate integration is performed away from aircraft
- short time between project start and test flights as antenna box is already certified
- uncompromised aircraft flight envelope

On the bottom side of the fuselage, several existing antenna positions can be used. The cabin provides space for installation of application and control systems in available standard racks.

### Aircraft

We operate a Cessna Citation II business type aircraft which has been modified for flight testing purposes. The aircraft has a pressurized cabin and can fly at high altitudes.

### Organisation

Our research aircraft operates in accordance with Part OPS. For the design, classification and approval of modifications, NLR holds an approval based on Part 21, while our maintenance organisation is Part 145 and Part-M approved.

### Personnel

Our experienced team of experts consists of qualified people like research pilots, flight test (instrumentation) engineers, R&D engineers, certifying staff, technicians and support personnel. NLR is flying test aircraft since 1920.

### Context

Our flight test facility is linked to other NLR capabilities. We can provide you a broader platform for aviation research in general and antennae ground testing services in particular.

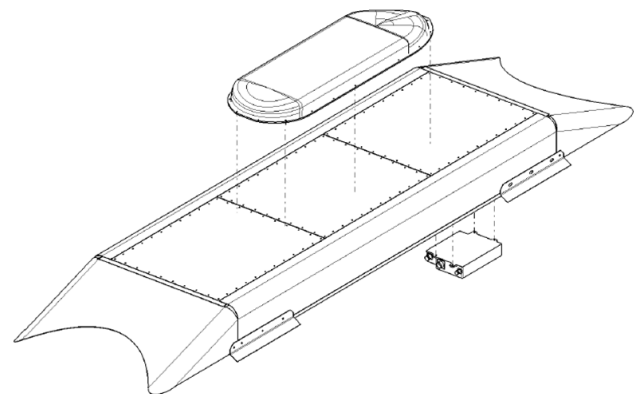

## PRODUCTS & FEATURES

- Affordable & flexible flight testing of antennae
- Quick & easy antennae integration on aircraft antenna box
- Operations from well accessible Amsterdam Airport Schiphol or elsewhere
- Low cost of business type aircraft, yet performance comparable to large aircraft
- Short time between project initiation and flight execution